

## Remote Environment Monitoring & Detection Tribot

Swati Kumari<sup>1</sup>, Sudeep Kumar Saha<sup>2</sup>

<sup>1</sup>Department of Electronics & Communication, Bharath University, Selaiyur, Chennai, Tamil Nadu, India

<sup>2</sup>Department of Electronics & Communication, SRM University, Kattankulathur, Chennai, Tamil Nadu, India

**Abstract:** Monitoring environment parameters is a complex task of great importance in many areas, such as the natural living environment; industrial or laboratory hazardous environments (biologically, radioactively, or chemically contaminated); polluted/toxic natural environments; water treatment plants; nuclear stations; or remote, difficult-to-reach environments, such as coal mines, unexplored area, etc. REMDT is a new generation of intelligent, autonomous, wireless robotic sensor agent (RSA) performing complex environment monitoring. Monitoring is done by continuously collecting sensory data from mobile RSA deployed in the field.

REMDT provides real-time information on the environment of the target area, such as temperature, humidity, light intensity, etc. REMDT is a combination of sensors, embedded system, artificial intelligence and wireless communication network. In our prototype of RMEDT we are monitoring a real time temperature of the environment in which the RSA is located. We are also implementing an artificial intelligence by providing object detection functionality and autonomous direction control decision algorithm. The RSA transmits continuous environmental temperature to a remote machine through wireless Zigbee communication. If an obstacle is detected near the RSA, the RSA will change its path accordingly so that a collision could be avoided.

**Keywords** - automated robot, environment monitoring, intelligent sensors, mobile agents, ZigBee

### I. INTRODUCTION

REMDT gives a real-time monitoring of the environment information on the target area, such as temperature, humidity, light intensity; etc. REMDT is a combination of sensors, embedded system, artificial intelligence and wireless communication network.

In our prototype of RMEDT we are monitoring a real time temperature of the environment in which the RSA is located. We are also implementing an artificial intelligence by providing object detection functionality and autonomous direction control decision algorithm.

The RSA transmits continuous environmental temperature to a remote machine through wireless Zigbee communication. If an obstacle is detected near the RSA, the RSA will change its path accordingly so that a collision could be avoided.

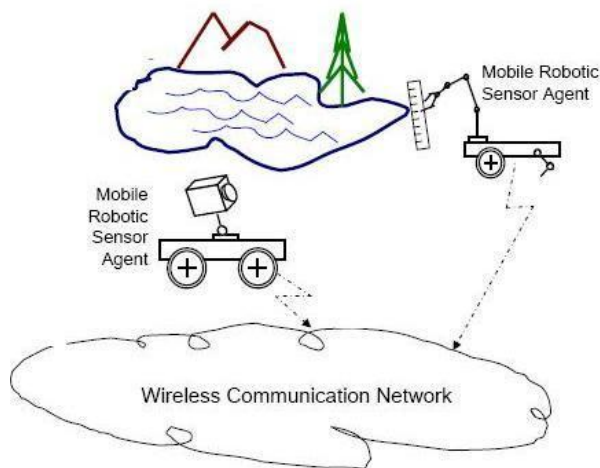

FIG 1 RSA in field

Block Diagram

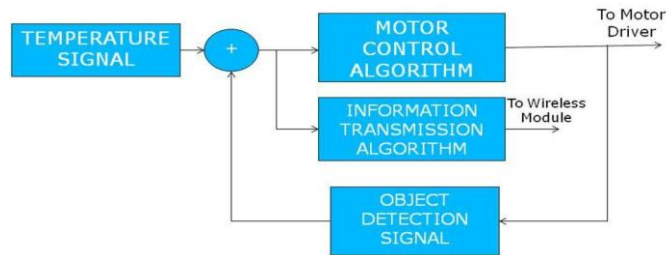

FIG 2 Block Diagram

REMDT receives temperature in degree centigrade as a continuous signal from sensor and transmits it to the Remote Machine. Another objective of REMDT is to travel autonomously on unknown plateau. To achieve this, three object detection sensors are used to detect nearby obstacles and provides a feedback signal to control the motion of the tribot.

Thus the control system of REMDT is a closed loop control system where the object detection sensor acts as a feedback sensor and motor acts as the actuator. The control signal is generated by the microcontroller which via a motor driver controls the action of the motor.

II. ROBOTIC SENSOR AGENT

RSA CIRCUIT DIAGRAM

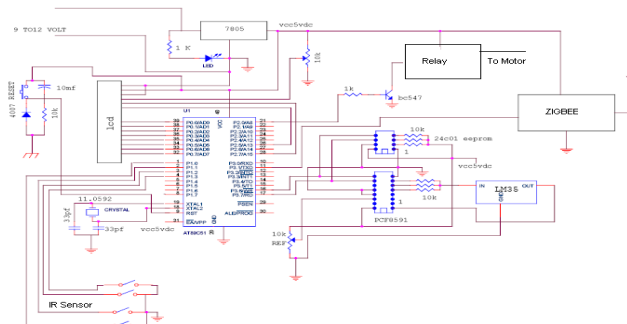

Fig. 3 Circuit diagram of Robotic Sensor Agent

The RSA circuit comprises of the following components –

- Microcontroller – AT89C51
- CMOS-RS232 Converter – IC MAX232
- Zigbee Module – Xbee OEM RF Modules
- Object Detection Sensor – Infra Red Sensor
- Temperature Sensor – LM35
- Analog-To-Digital Converter – PCF 8591
- Logical Inverter – IC 7404
- Voltage Regulator – LM7805
- DC Motor
- 5V DC Relay
- 12V DC Battery

A. Zigbee Module – Xbee OEM RF Modules

The Xbee OEM RF Modules were engineered to meet IEEE 802.15.4 standards and support the unique needs of low-cost, low-power wireless sensor networks.

The modules require minimal power and provide reliable delivery of data between devices. The modules operate within the 2.4 GHz frequency band and are pin-for-pin compatible with each other.



Fig 4 RF Module

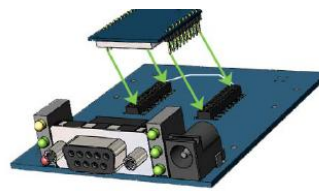

Fig 5 XBee Mounting

### B. Object Detection Sensor – Infra Red Sensor

The basic idea is to send infra red light through IR-LEDs, which is then reflected by an object in front of the sensor.

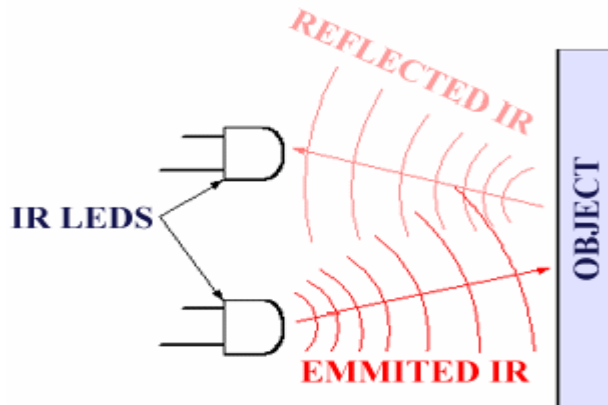

Fig 6 Object Detection using Infrared Sensor

Then all you have to do is to pick-up the reflected IR light. For detecting the reflected IR light, we have used another IR-LED, to detect the IR light that was emitted from another led.

This is an electrical property of Light Emitting Diodes (LEDs) which is the fact that a led produces a voltage difference across its leads when it is subjected to light. As if it was a photo-cell, but with much lower output current. In other words, the voltage generated by the led can't be - in any way - used to generate electrical power from light, it can barely be detected. That's why we have used an Op-Amp (operational Amplifier) to accurately detect very small voltage changes.

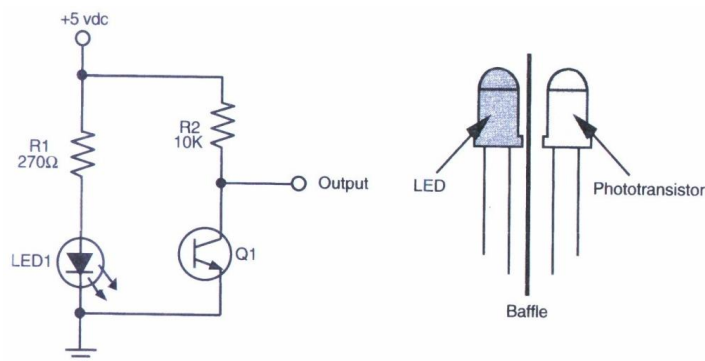

Fig 7 Infrared Object Detection Sensor

### C. Temperature Sensor – LM35

The LM35 series are precision integrated-circuit temperature sensors, whose output voltage is linearly proportional to the Celsius (Centigrade) temperature. The LM35 thus has an advantage over linear temperature sensors calibrated in ° Kelvin, as the user is not required to subtract a large constant voltage from its output to obtain convenient Centigrade scaling. The LM35 does not require any external calibration or trimming to provide typical accuracies of  $\pm 1/4^{\circ}\text{C}$  at room temperature and  $\pm 3/4^{\circ}\text{C}$  over a full  $-55$  to  $+150^{\circ}\text{C}$  temperature range.

Low cost is assured by trimming and calibration at the wafer level. The LM35's low output impedance, linear output, and precise inherent calibration make interfacing to readout or control circuitry especially easy. It can be

used with single power supplies, or with plus and minus supplies. As it draws only 60  $\mu\text{A}$  from its supply, it has very low self-heating, less than  $0.1^\circ\text{C}$  in still air. The LM35 is rated to operate over a  $-55^\circ$  to  $+150^\circ\text{C}$  temperature range, while the LM35C is rated for a  $-40^\circ$  to  $+110^\circ\text{C}$  range ( $-10^\circ$  with improved accuracy). The LM35 series is available packaged in hermetic TO-46 transistor packages, while the LM35C, LM35CA, and LM35D are also available in the plastic TO-92 transistor package. The LM35D is also available in an 8-lead surface mount small outline package and a plastic TO-220 package.

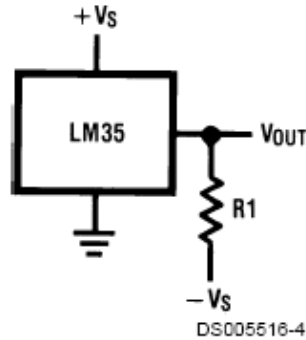

Choose  $R_1 = -V_S/50 \mu\text{A}$   
 $V_{OUT} = +1,500 \text{ mV at } +150^\circ\text{C}$   
 $= +250 \text{ mV at } +25^\circ\text{C}$   
 $= -550 \text{ mV at } -55^\circ\text{C}$

Fig 8 Full-Range Centigrade Temperature Sensor

### III. REMOTE MACHINE

Remote Machine consists of Information receiving unit and monitoring and control panel.

#### A. Information Receiving Unit

The information receiving unit consists of the following components

- Zigbee Module – XBee Pro
- IC MAX232
- DB-9 Socket

The main purpose of this unit is to create link with the RSA in field and receive temperature information from the LM35 temperature sensor. This unit also transmits control signals for starting and stopping the RSA.

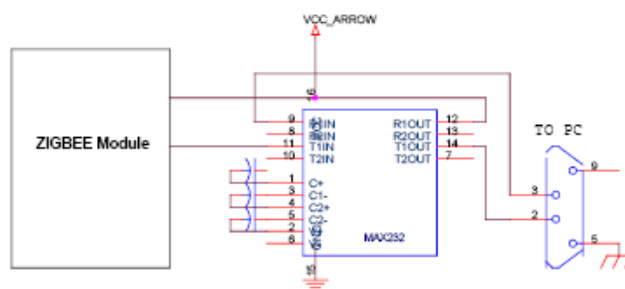

Fig 9 Circuit Diagram of Information Receiving Unit

#### B. Monitoring & Control Panel

Monitoring and Control Panel is designed using Visual Basic software. Visual Basic packaged with Visual Studio 2005 provides a rich graphical user interface. The Monitoring Panel consists of a graph between real time temperature vs time. Three set points have been set for the temperature for indicating either, Normal Temperature ( $20 - 50 \text{ C}$ ), Low Temperature ( $<20 \text{ C}$ ) or High Temperature ( $>50 \text{ C}$ ).

The application can be used to control the tribot by use of the start and stop button.

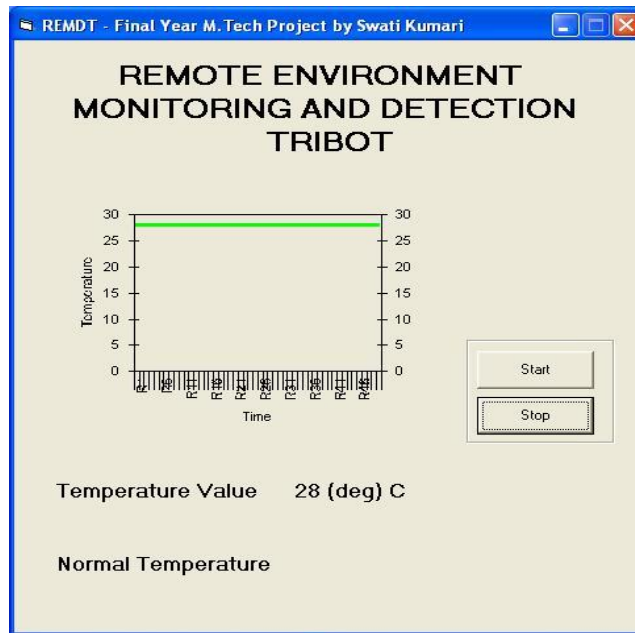

Fig 10 REMDT Application

#### IV. FLOW DIAGRAM

##### A. Robotic Sensor Agent Flowchart

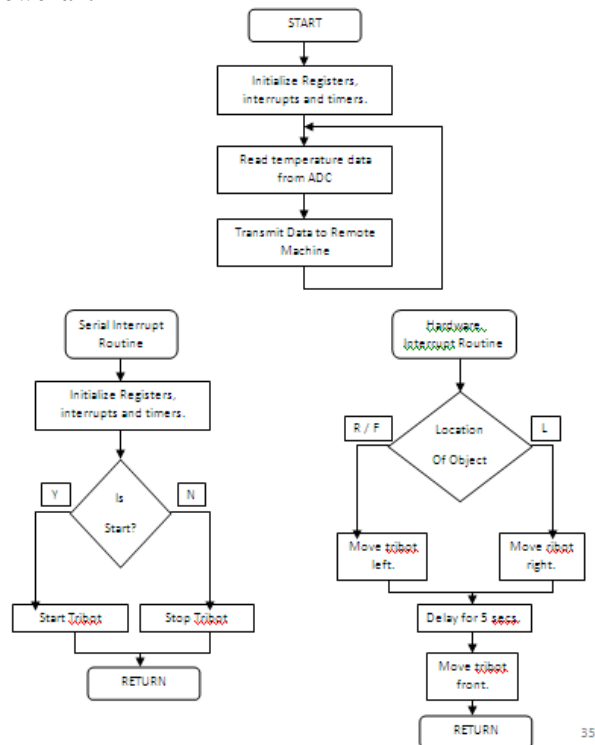

Fig 11 Robotic Sensor Agent Flowchart

##### B. REMDT Application Flowchart

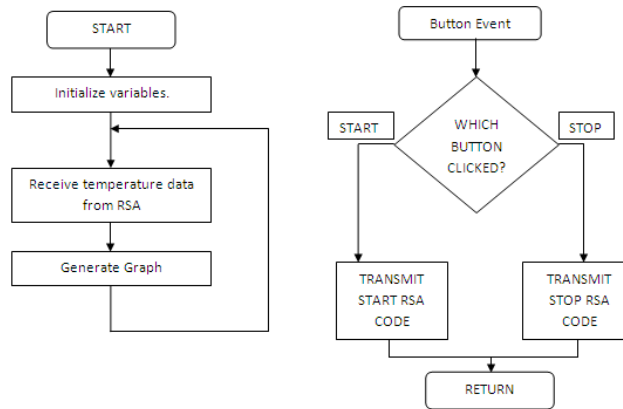

Fig 11 REMDT Application Flowchart

### V. SOFTWARE SIMULATION

The real time software for the motherboard is designed using Embedded C. The program has been successfully compiled and debugged in Keil uVision.

Few screenshots of the software simulation are given below.

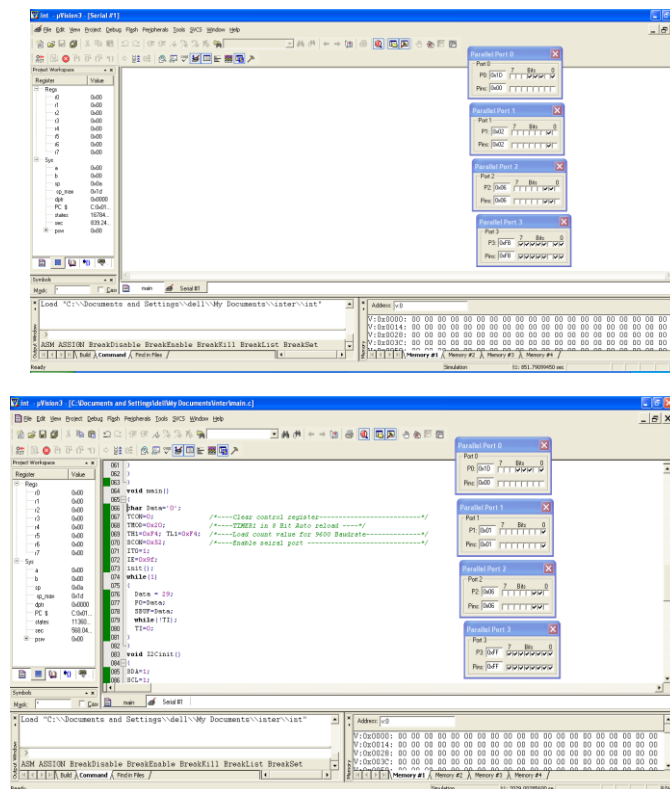

FIG 12 RSA PROGRAM SIMULATION

### VI. RSA IN ACTION

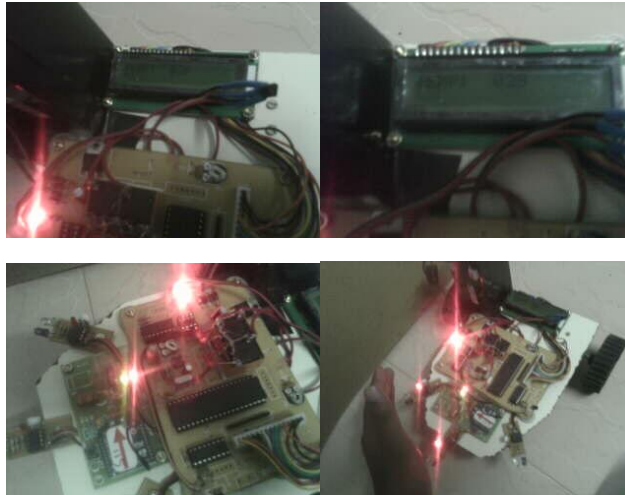

FIG 13 ROBOTIC SENSOR AGENT SNAPSHOTS

## VII. CONCLUSION

Remote Environment Monitoring & Detection System currently monitors environmental temperature and detects for any obstacles and changes its path accordingly. The measured temperature is transmitted to a remote machine running the REMDT application. A trend graph displays continuous temperature. The temperature data can also be stored for future reference.

The RSA developed is completely autonomous, i.e., if any obstacle comes in its way, it detects the obstacles and intelligently changes its path. So an artificial intelligence has been incorporated into the Robotic Sensor Agent to perform operations on the field unmonitored and unattended. A manual overriding is possible by the ability to stop the RSA from the Remote Machine.

The REMDT is a low cost tribot. A single RSA would cost less than Rs. 10,000 and in case of large production the cost would further decrease. The cost of the RSA also depends upon the sensors. On interfacing additional sensors the cost would gradually increase.

### Future Scope

By interfacing additional sensors the functionality of the REMDT can be further increased.

For example,

- Global Positioning System – Position Monitoring.
- Hygrometer – Humidity Monitoring.
- Chromatography Sensor – Chemical Contamination Monitoring.
- Geiger counter – Radioactive / Nuclear Waste Monitoring.
- Gas Detector – Harmful Gas Leakage Monitoring.
- Seismometers – Monitoring motion of ground.
- Soil Moisture Sensor – Monitoring water content in soil.

The sensors can be interfaced with the microcontroller located on the Robotic Sensor Agent. On adding any new sensor the RSA microcontroller program as well as the REMDT application has to be modified. For example, on addition of hygrometer sensor, the RSA program should be modified to take humidity data as input and transmit it along with temperature data. In REMDT application a trend graph for humidity monitoring has to be generated as well.

## REFERENCES

- [1] J. Birnbaum, "Pervasive Information Systems", Communications of the ACM, Vol.40, No.2, pp. 40-41, 1997
- [2] M. Satyanarayanan, "Pervasive computing: vision and challenges," IEEE Personal Communications, Vol. 8, No. 4, pp. 10 – 17, 2001
- [3] G.D. Abowd and J.P.G. Sterbenz, "Final report on the inter-agency workshop on research issues for smart environments," IEEE Personal Communications, Vol. 7, No. 5 pp. 36 – 40, 2000

- [4] A. Schmidt, and K. van Laerhoven, "How to build smart appliances?" IEEE Personal Communications, Vol. 8, No. 4, pp. 66 - 71, 2001
- [5] G. Fortino, D. Grimaldi, L. Nigro, "Multicast Control of Mobile Measurement Systems," IEEE Trans. Instrum. Meas., Vol.47, No.5, pp.1149-1154, 1998
- [6] M. Bertocco, F. Ferraris, C. Offelli, M. Parvis, "A client-server architecture for distributed measurement system", IEEE Trans. Instrum. Meas., vol. 47, pp.1143-1148, 1998
- [7] L. Cristaldi, A. Ferrero, and V. Piuri, "Programmable instruments, virtual instruments, and distributed measurement systems: what is really useful, innovative and technically sound?" IEEE Instr. Meas. Magazine, Vol. 2, No. 3, pp. 20 - 27, 1999
- [8] K. Sohrabi, J. Gao, V. Ailawadhi, and G.J. Pottie, "Protocols for selforganization of a wireless sensor network," IEEE Personal Communications, Vol. 7, No. 5, pp. 16 -27, 2000
- [9] C-P. Young; W-L. Juang, and M.J. Devaney, "Real-time Intranetcontrolled virtual instrument multiple-circuit power monitoring," IEEE Trans. Instrum. Meas., Vol.49, No. 3, pp. 579 - 584, 2000